

BRAVILOR[®] **BONAMAT**

Operating instructions
COFFEE BREWER

GB

Mode d'emploi
MACHINE À CAFÉ

FR

Gebrauchsanleitung
KAFFEEBRÜHMASCHINE

DE

Gebruiksaanwijzing
KOFFIEZETAPPARAAT

NL

Bruksanvisning
KAFFEBRYGGARE

SE

Bruksanvisning
KAFFEMASKIN

NO

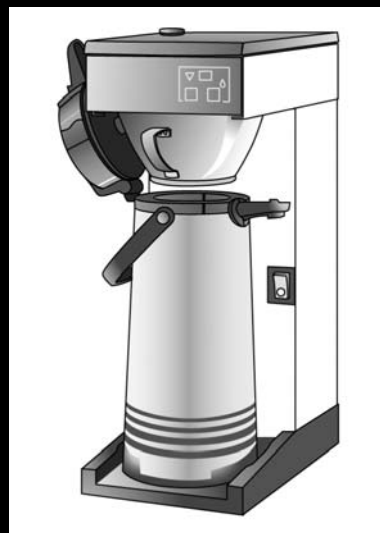
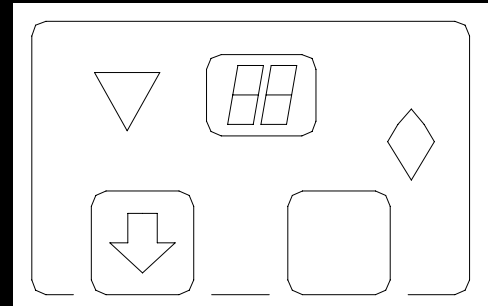

Matic / THa

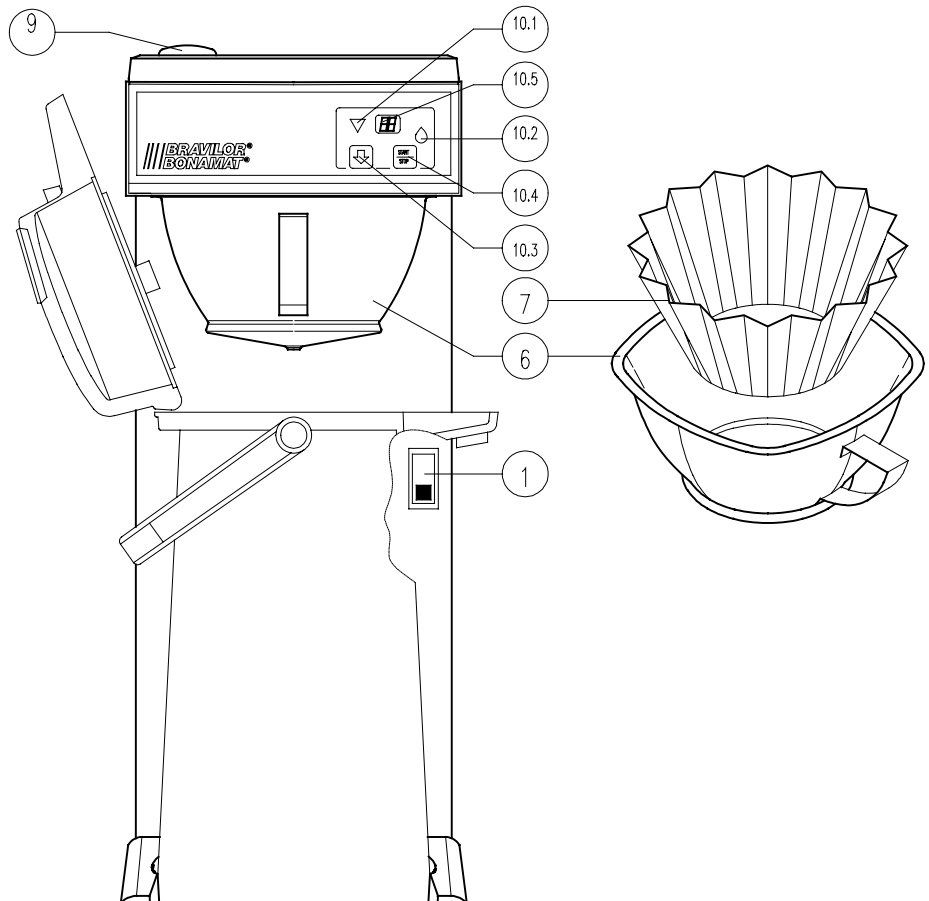
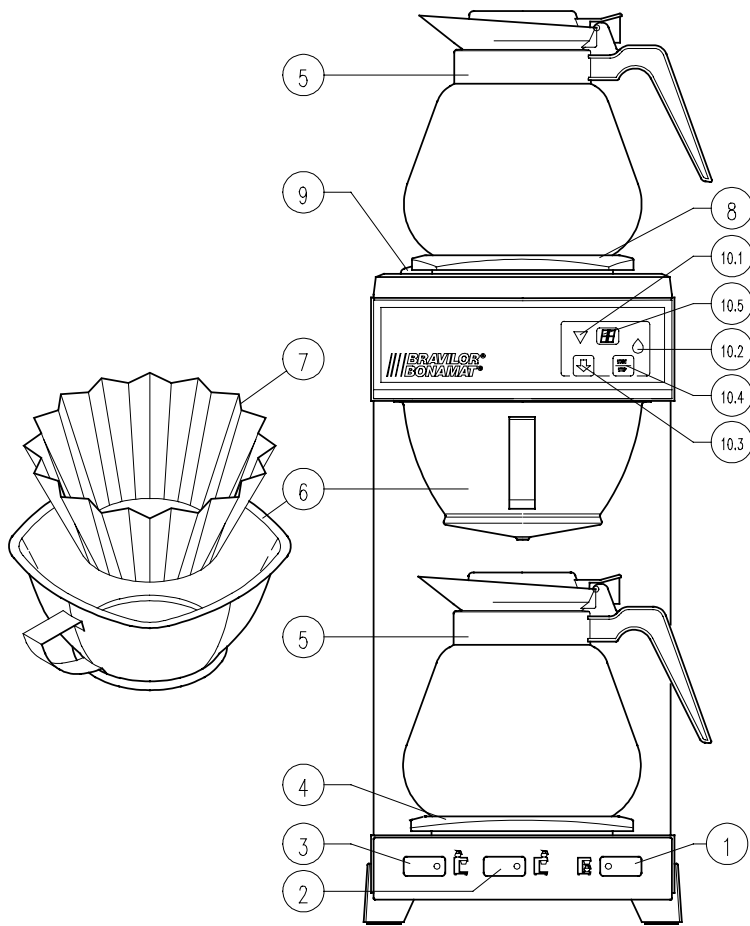

1.1 Introduction

We are delighted that you have chosen one of our quality products. The machines have been specifically designed for brewing coffee and/or tea.

Please read these operating instructions carefully to ensure correct and safe use of the coffee-maker and benefit fully from its use.

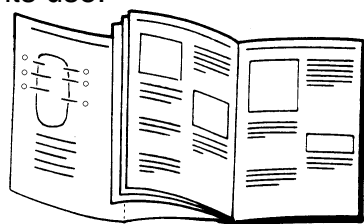

Keep the fold out sheet opened while reading the instructions.

Contents:	Page
1.1 INTRODUCTION	2
1.2 MODELS AND TYPES	2
1.3 WARNINGS AND PRECAUTIONS	3
1.4 A QUICK GLANCE AT THE MACHINE	4
1.5 INSTALLATION AND OPERATION	5
1.6 ADJUST THE QUANTITY OF WATER.....	5
1.7 USAGE	6
1.8 CLEANING	7
1.9 DESCALING	7
1.10 TROUBLE SHOOTING.....	8

1.2 Models and types

These operating instructions apply to the following coffee makers:

MTC2-021
MTC3-021

THA10-021
THA20-021

MTC2WB-021
MTCTW-021

(For the drawings please refer to the last page of this manual).

For information regarding capacity, model and type numbers etc., please see the type plate on the machine. Note the information in the back of this manual.



1.3 Warnings and precautions

The following warnings and precautions must be observed to ensure the safe use of the coffee-maker:

WARNINGS

- △ Never immerse the machine in water.
- △ Remain in the vicinity of the machine during maintenance activities, such as descaling.
- △ Ensure the flex does not touch the hot plate.
- △ The machine should at all times be connected to the water supply and the electricity mains supply in such a way that it can easily be disconnected.
- △ The machine must always be connected to the electricity mains so that all wires are easy to disconnect from the mains.
- △ The manufacturer shall accept no liability for damage resulting from installation, use or maintenance activities that are not described in these operating instructions.
- △ Some parts of the equipment will become very hot during use.
- △ Do not use any sharp objects to operate the machine.

PRECAUTIONS

- If the equipment is not used for a long period, it is advisable to disconnect it from the mains.
- It is normal for some water to remain in the machine. This should be taken into account if the machine is moved to a location where the temperature may fall below freezing point.
- If all the water has been removed from the machine, the instructions for "Installation and operation" should be carried out again.
- If you use an aggressive cleaner or descaler, it is highly advisable to wear safety goggles (face protection) and gloves.
- Avoid spilling any descaling solution on the outside of the machine, since this may result in permanent damage to the housing. However, should descaler come into contact with the outside of the machine, it must be removed as quickly as possible by observing the safety precautions described in these operating instructions. The point of contact must be cleaned immediately and thoroughly.
- Always wash your hands after using an aggressive cleaner or descaler.
- Have all repair work carried out by a qualified service engineer.
- In the case of repair and/or maintenance activities in which the machine must be opened, all wires including the earth wire must be disconnected from the mains.
- The machine must have an earth connection.
- Always use approved materials and components during installation.
- The machine should be connected to the water supply at all times via a tap that can be operated manually.
- During the installation activities, always observe local regulations and standards.



1.4 A quick glance at the machine

The most important parts of the machine are listed on the fold out sheet. Keep this sheet opened  while reading the instructions.

1. On/off switch for the machine and the hot plate under the filter.
2. On/off switch for the hot plate (see pictogram for position).
3. On/off switch for the hot plate (see pictogram for position).
4. Hot plate under the filter
5. Glass decanter, vacuum flask or Airpot
6. Filter pan
7. Coffee filter (paper)
8. Upper hot plate (independent)
9. Opening for descaler
10. Control panel
 - 10.1 Descaler indicator
 - 10.2 In use indicator
 - 10.3 Select key (↓)
 - 10.4 1/0-Key (= Start/stop key)
 - 10.5 Display

INDICATORS



The green light indicates that the machine is busy brewing coffee. Coffee will be brewed while the green light is on. At the end of the brewing process, an acoustic signal will sound three times and the green light will go off.

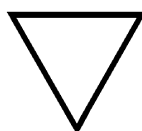

If the red descale indicator (10.1) flashes, the machine needs to be de-scaled. However, it is still possible to brew coffee a couple more times, until a suitable moment for descaling occurs.

RECOMMENDED AMOUNTS OF COFFEE

Use 35 to 50 grams of ground coffee (filter fine) per litre, depending on your taste.

Glass decanter:

1.7 litres 60-85 grams

Vacuum flask or airpot:

1.9 litres 65-95 grams

2.2 litres 75-110 grams

The enclosed measuring spoon filled with a level amount of coffee contains approx. 40 grams.

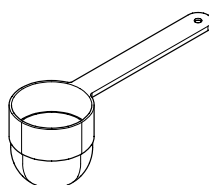

Measuring spoon

ACCESSORIES	Matic 2	Matic 3	Tha 10/Tha 20	Matic2 WB	Matic Twin
Glass decanter	2	3	--	2	4
Filter pan + spring	1	1	1	1	2
Filter paper (bag)	1	1	1	1	1
Cleaner	1	1	1	1	1
Renegite	1	1	1	1	1
Measuring spoon	1	1	1	1	1
Funnel	1	1	1	1	1
Water supply connection	1	1	1	1	1



1.5 Installation and operation

1. Place the machine on the work surface.
2. Check whether the machine is positioned steady and horizontally.
3. Make sure there is an earthed mains connection and water supply in the close vicinity.
4. Connect the machine to the water supply (with a tap) using the connecting hose supplied.
5. Slide an empty filter pan (6) into position and place an empty decanter (5) beneath it. CAUTION! The lid of the vacuum flask or airpot must be opened for the THA model. Keep the mixing tube in the flask when using an airpot.
6. Set all the switches (1, 2 and 3, if present) to "off".
7. Put the plug in the wall socket. (earthed).
8. Turn the machine on by setting the switch (1) to "on". The switch lamp will come on. The lamps (10.1, 10.2) and the display will light up briefly. The display will then indicate the standard number of cups.
9. Press the $\frac{1}{0}$ -key. You will hear an acoustic signal.
10. Wait for about 3 minutes. If the water has still not started flowing, press the $\frac{1}{0}$ -key again.
11. The decanter will now start to fill.
12. Once the water has stopped flowing, you will hear a three-note acoustic signal after 1 minute. Now you can empty the decanter.

The machine is now ready for use.

Remarks:

1. Some water will always remain in the machine, its hoses, boiler, etc. This must be taken into account when:
 - moving the machine
 - the machine is situated in a room where the temperature falls below freezing point.
2. If, for any reason, no water is left in the machine, you must repeat the above procedure (from step 5 to 12).

WARNING



Ensure the flex does not touch the heating plate.

1.6 Adjust the quantity of water

You can adjust the quantity of hot water used to brew the coffee. This is set to a standard amount when the machine leaves the factory. If you think this setting is supplying too much or too little water, you can change the amount as follows:

1. Press the \downarrow - and the $\frac{1}{0}$ -keys at the same time and keep them pressed in until P1 appears in the display (after about 15 seconds).
2. Release the keys. The display will now show the setting for the current quantity of water. This quantity varies from machine to machine.

3. Press the \downarrow -key for more water or the $\frac{1}{0}$ -key for less.
 4. The settings available range from 0, 2, 4, 6... to 98. Two steps higher will give you 3,3 to 5 ml extra water in the decanter. Wait for about 20 seconds.
- The machine is now ready for use.

For other settings of the hot water quantity, see the table on the fold out sheet at the back of this manual.



1.7 Usage

1. Before using the machine, check whether the spring in the filter pan (6) is positioned correctly (the spring must be flat on the bottom of the filter pan).
2. Place a paper filter (7) in the filter pan.
3. Put the required amount of coffee in the filter (see § 1.4 **RECOMMENDED AMOUNTS OF COFFEE**).
4. The enclosed measuring spoon filled with a level amount of coffee contains approx. 40 grams.
5. Slide the filter pan (6) into the machine.
6. Check whether the machine is switched on. If not, switch the machine on by setting switch (1) to the "on" position. The lamp in the switch will come on.
7. Place the decanter under the filter pan.
 - Ensure that the lid of the glass decanter is in the down position.
 - The lid of the vacuum flask or airpot, on the other hand, must be in the up position.
 - Keep the double mixing tube in the flask when using an airpot.
8. Select the required quantity using the ↓-key.
9. Press the $\frac{1}{0}$ -key. You will hear an acoustic signal.
10. The green light (10.2) will come on and the coffee brewing cycle will start.
11. When the brewing cycle has finished, the indication lamp (10.2) will go out and an acoustic signal will sound three times to indicate that the coffee can be poured.

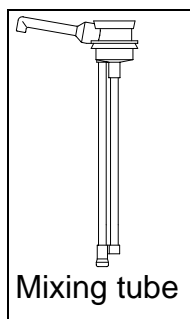

12. Using the model with glass decanters and more than one hot plate, it is possible to place a decanter filled with coffee on another hot plate and immediately brew another decanter by observing the above procedure.
13. Switch on the second hot plate by setting the switch (2 or 3) to "on" (the switch lamp will come on).
14. Reset the switch to the "off" position, when the extra hot plate is no longer in use.

BREWING TEA

The machine can also be used to make tea. The system is the same as for brewing coffee except that, instead of using coffee filters and coffee, you place loose tea or tea bags in the filter pan.

- There is a special tea filter pan (with a sieve) available if you want to use loose tea.
- If you use tea bags, simply place these in the filter pan or suspend them in the decanter.

Note! Never use a filter pan that has been used for making coffee. Remains of the coffee can give the tea an unpleasant taste.

STOPPING THE BREWING CYCLE

You can stop the brewing cycle by pressing the $\frac{1}{0}$ -key. When you next start the cycle, the whole process will start again from the beginning. You need to take this into account if the decanter is already partially full. You may have to press the ↓-key to select a different quantity.

WARNING



Some parts of the equipment will become very hot during use.



1.8 Cleaning

It is important that the machine and the accessories be kept clean. It is best to clean the machine with a damp cloth, if necessary with a non-abrasive and/or corrosive detergent. The glass decanters and the filter pan can be washed normally and subsequently rinsed thoroughly with water. Vacuum flasks and airpots can be rinsed with hot water. Our **Cleaner** is recommended for removing all coffee and tea deposits.

The cleaning procedure itself is simple:

CLEANING GLASS DECANTERS AND FILTER PAN

1. Dissolve 1 sachet of **Cleaner** in 5 litres of hot water (min. 80 °C).
2. Place the items to be cleaned in the solution. For a good result, the spring must be removed from the filter pan.

3. Leave the parts to soak (max. 30 minutes).
4. Pour the **Cleaner** solution away.
5. Now rinse the items with plenty of hot water.
6. Do not forget to replace the spring in the filter pan.

CLEANING VACUUM FLASKS AND AIRPOTS

1. Dissolve **Cleaner** in hot water (min. 80 °C), approx. 5 g/l.
2. Fill the vacuum flask(s) and/or airpot(s) with this **Cleaner** solution.
3. Leave the solution to soak for approx. 30 minutes and then pour it away.
4. Rinse the decanters several times with hot water.

PRECAUTION



*Always wear protective gloves when using **Cleaner**!*

1.9 Descaling

In hard water areas, chalk and limescale will accumulate when the machine is used. The machine is fitted with a descale indicator that is activated if scale deposits exceed a certain level. If this descale indicator is activated (the lamp in the red triangle (10.1) starts to flash), the scale must be removed from the machine. Correct operation can otherwise not be guaranteed. When the red light starts to flash, it is still possible to brew coffee a couple more times. The operator can then wait until a suitable time to descale the machine.

The descaling procedure is as follows:

1. First read the instructions and recommendations on the sachet of the descaling agent. We recommend using our tried and tested **Renegite** descaling agent.
2. Dissolve 100 g **Renegite** in 0,5 litre of hot water.
3. Slide the empty filter pan (6) into the machine and place an empty decanter beneath it.

4. Use the funnel to pour half of the **RENEGITE** solution carefully into the opening (9).
5. Switch the machine on using switch (1). Use the ↓-key (10.3) to select 2 cups and press the $\frac{1}{0}$ -key. The solution will drip into the decanter.
6. Wait for 2 minutes. The **Renegite** solution is now given time to perform its task.
7. Repeat points 4 and 5.
8. Empty the decanter.
9. The machine must now be rinsed with fresh water by running the normal brewing process twice without using any coffee. Do not forget to empty the decanter between each rinse.

The machine is again ready for making coffee.

PRECAUTIONS



- *Remain in the vicinity of the machine during all descaling activities.*
- *Wear gloves and face protection during all descaling activities.*



1.10 Trouble shooting

In case of malfunction, first consult this troubleshooting list. If the problem cannot be solved with the aid of this list, please consult your supplier or your service engineer.

WARNING



If the machine is to be opened, e.g. in the case of repairs, the plug must first be removed from the wall socket.

TROUBLE SHOOTING LIST

MALFUNCTION:	POSSIBLE CAUSE:	SOLUTION:
<ul style="list-style-type: none"> The machine is not working and the switch lamps are not on. 	<ul style="list-style-type: none"> The external fuse has blown; the circuit has overloaded. 	<ul style="list-style-type: none"> Change the appropriate fuse. Operate the machine on a separate circuit.
<ul style="list-style-type: none"> The descale indicator is flashing. 	<ul style="list-style-type: none"> The accumulation of scale exceeds the critical limit. 	<ul style="list-style-type: none"> Descalate the machine, see § 1.9.
<ul style="list-style-type: none"> The descale indicator continues to flash after descaling. 	<ul style="list-style-type: none"> The accumulation of scale is excessive. 	<ul style="list-style-type: none"> Descalate the machine again. If the descale lamp continues to flash, ring your supplier or service engineer.
<ul style="list-style-type: none"> The filter pan overflows. 	<ul style="list-style-type: none"> The filter pan spring is not in place. 	<ul style="list-style-type: none"> Place the filter pan spring in the filter pan.
<ul style="list-style-type: none"> The machine does not supply quite enough coffee. 	<ul style="list-style-type: none"> Not enough water has been set at P1. 	<ul style="list-style-type: none"> The P1 quantity setting, see § 1.6, should be changed.
<ul style="list-style-type: none"> The decanter overflows. 	<ul style="list-style-type: none"> Too much water has been set at P1. 	<ul style="list-style-type: none"> The P1 quantity setting, see § 1.6, should be changed.
<ul style="list-style-type: none"> You get only a small amount of coffee in the decanter - or none at all. 	<ul style="list-style-type: none"> The safety mechanism in the water supply system has come on because: <ul style="list-style-type: none"> A. The flow of water has been blocked. B. Water pressure is too low. 	<ul style="list-style-type: none"> A.1 The water tap is still turned off. Turn it on. A.2 Turn off the water tap. Uncouple the supply pipe at both ends and remove any blockages present. B. Ring the service engineer.

SUBJECT TO MODIFICATION





BRAVILOR[®]
BONAMAT

COFFEE BREWING MACHINES
MACHINES A CAFE
KAFFEEBRUEHMASCHINEN
KOFFIEZETAPPARATEN

© 12-1996

700.403.207 C